



**Test report EN 10204/2.2**

**Number 326308**

Our order **0211158230 / 10**

Customer order **MAIL 12.08.2013**

Consegna **0221206811**

delivery **0000219920**

Messrs

**DYWIDAG-SYSTEMS INTERNATIONAL GMBH**

**ALFRED-WAGNER-STRASSE 1**

**4061 PASCHING**

**AT**

Description **TUBE FIN CUT**

Standard **EN 10296-1 EW**

**Standard**

**Steel grade**

Steel grade **E355 +U**

Dimensions **MEC 114,3X6X6050 NL ERWE355 +U**

**Chemical analysis**

**Chemical composition**

	C	Mn	Si	P	S	Al	Cr	Ni	Mo	Cu	Sn	V	Nb	Ti	B	N
min						0,0200										
max	0,2400	1,7000	0,6000	0,0500	0,0500											
<b>3041081A</b>	0,1681	1,2643	0,1862	0,0074	0,0020	0,0228										
<b>3041081B</b>	0,1836	1,4497	0,2143	0,0157	0,0046	0,0286										

試験で求められる項目R(MPa), REH(MPa), A(%)それぞれ

**Mechanical and technological**

**Mechanical properties**

Works Nr.	Heat	Lot	Tubes	R (MPa)		REH (MPa)		A(%)		Rs/R	Fm (N)
				>= 510		>= 355		>= 22,0			
<b>1 3041081</b>	<b>3041081A</b>		<b>51</b>	575		450		27,50			
<b>2 3041081</b>	<b>3041081B</b>		<b>20</b>	570		445		29,00			

--

Test	Standard	Required	-	Result
Non destructive test	EN ISO 10893-2	E3H	% 100	<b>POSITIVE</b>
Dimensional inspection	EN 10296-1		1	<b>POSITIVE</b>
Flattening test	EN ISO 8492		1	<b>POSITIVE</b>
Visual	EN 10296-1		1	<b>POSITIVE</b>

Remarks

**QUALITY DEPARTMENT**

Tel. +39 0372 4091

Fax +39 0372 409349

e-mail: controllo.qualita@ata.arvedi.it

We hereby certify, that the material described above has been tested and complies with the terms of the order contract. This certificate has been created by a data processing system and does not contain a personal signature but the name and the official address of the appointed department.



Parts list / Stückliste					
Pos.	Pcs.	Drawing-No.	Article-No.	Description	Benennung
1	1	503017061003	503017061003	AT-114 Extension tube SC 6.0 [mm], EL 2,790 [mm]	AT-114 Verlängerungsrohr PV 6.0 [mm], WL 2,790 [mm]

先頭管

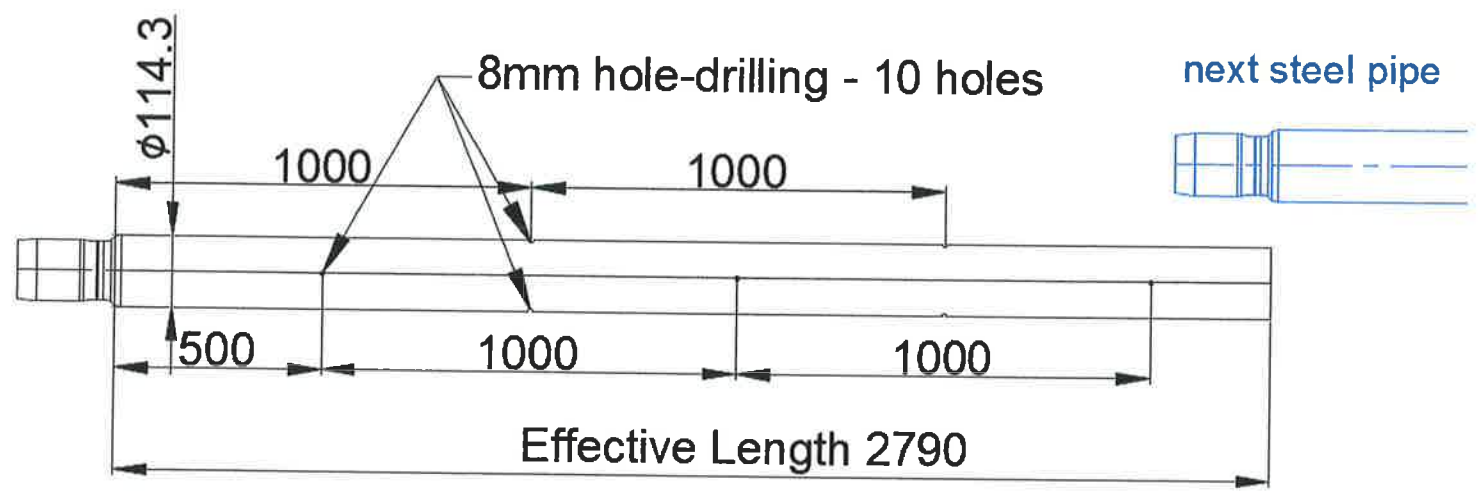

AT-114 Extension tube SC 6.0 [mm], EL 2790 [mm]



Maßstab		Gewicht 54.5kg	Werkstoff Nr.:
		Freimaßtol.	Werkstoff, Halbzeug:
Datum		Name	AT-114 Extension tube SC 6.0 [mm], EL 2,790 [mm]
Bearb:			
Gepr:			
Norm			
Freigabe			Artikel-Nr.: 503017061003
Projekt			Zeichn.-Nr.: 503017061003
<small>Gegenstand aller Unterlagen / Zeichnung ist unser geistiges Eigentum. Diese Zeichnung darf ohne unsere vorherige schriftliche Zustimmung nicht veröffentlicht, noch Dritten zur Benützung gestattet werden. Sie darf auch nicht in anderer Weise irrtümlich verändert werden.</small>			
Bez.	Änderung	Datum	Name
(Urheberrechtsgesetz v. 09.09.1965)			<small>DSI Underground Australia GmbH A/181 Baggara St., A-4061 Puchberg/Luz Phone: +43 22344 1000 Fax: +43 22344 1000</small>
			Format A3 Blatt 1

Parts list / Stückliste					
Pos.	Pcs.	Drawing-No.	Article-No.	Description	Benennung
1	1	503017061003	503017061003	AT-114 Extension tube SC 6.0 [mm], EL 3,050 [mm]	AT-114 Verlängerungsrohr PV 6.0 [mm], WL 3.050 [mm]

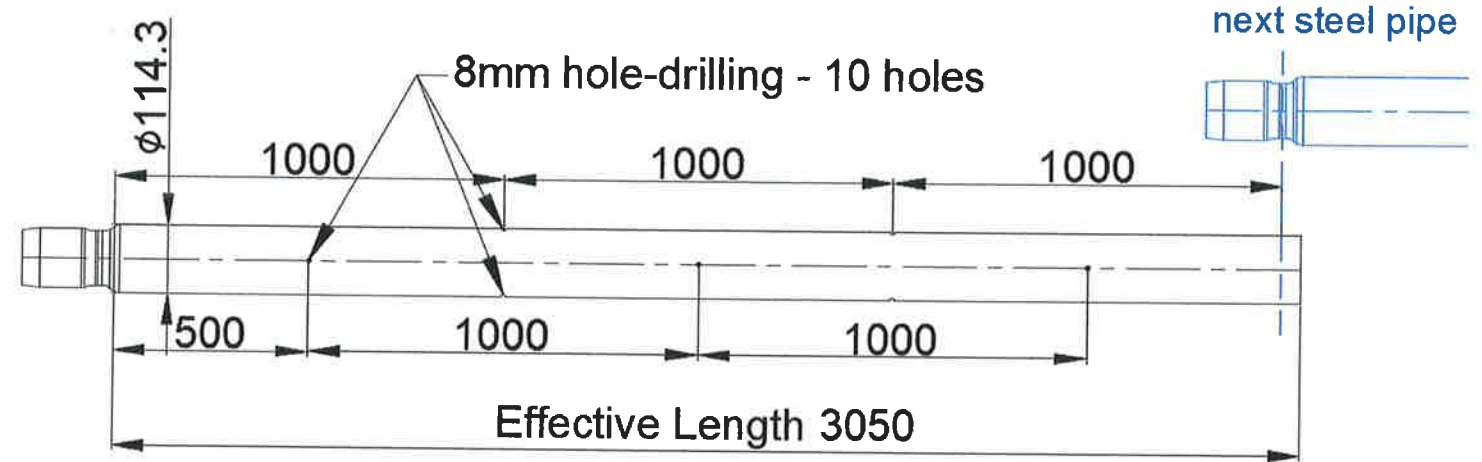
中間管



AT-114 Extension tube SC 6.0 [mm], EL 3050 [mm]

Maßstab		Gewicht 54.5kg		Werkstoff Nr.:	
Freimaßtol.		Freimaßtol.		Werkstoff, Halbzeug:	
Datum		Name		AT-114 Extension tube SC 6.0 [mm], EL 3,050 [mm]	
Bearb:					
Gepr:					
Norm					
Freigabe		Artikel-Nr.: 503017061003			
Projekt		Zeichn.-Nr.: 503017061003			
<small>Gegenstand der Urheberschaft / Zeichnung ist unser geistiges Eigentum. Diese Zeichnung darf ohne unsere schriftliche Zustimmung weder ververvielt noch Dritten zur Kenntnis gebracht werden. Sie darf auch nicht in anderer Weise nachträglich verwendet werden. (Urheberrechtsgesetz v. 09.09.1965)</small>					
Bez.	Änderung	Datum	Name	 	
				DSI Underground Austria GmbH Alpenstrasse 201, A-4051 Pasching/Leitz Phone: +43 7342 7010 E-Mail: office@dsi-systems.at	
				Format A3 Blatt 1	

Parts list / Stückliste					
Pos.	Pcs.	Drawing-No.	Article-No.	Description	Benennung
1	1	503017061003	503017061003	AT-114 End tube SC 6.0 [mm], EL 3,050 [mm]	AT-114 Verlängerungsrohr PV 6.0 [mm], WL 3.050 [mm]

端末管

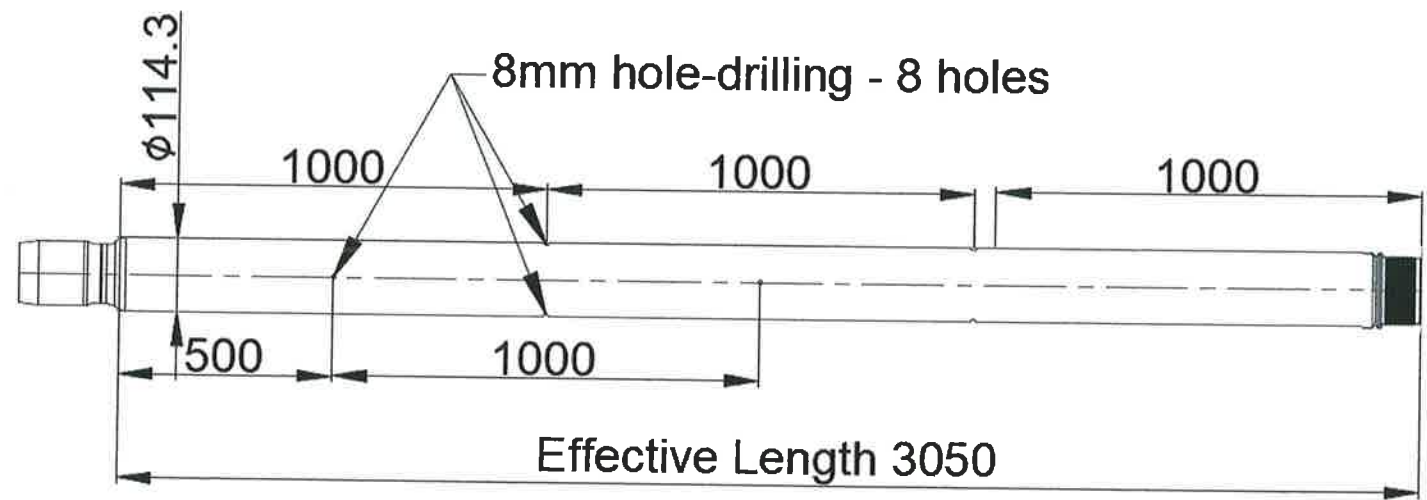

AT-114 End tube SC 6.0 [mm], EL 3050 [mm]

Maßstab		Gewicht 54.5kg	Werkstoff Nr.:
Datum		Freimaßtol.	Werkstoff, Halbzeug:
Name		AT-114 End tube SC 6.0 [mm], EL 3,050 [mm]	
Bearb:		Artikel-Nr.: 503017061003	
Gepr:		Zeichn.-Nr.: 503017061003	
Norm:			
Freigabe:			
Projekt:			
<small>Gegenstand der Urheber- / Zeichnung ist unser geistiges Eigentum. Diese Zeichnung darf ohne unsere vorherige schriftliche Zustimmung weder vervielfältigt noch Dritten zur Kenntnis gebracht werden. Sie darf auch nicht in anderer Weise publiziert oder verwendet werden.</small>			
Bez.	Änderung	Datum	Name
		<small>DSI Underground Austria GmbH Karl-Wagner-Str. 1, A-4601 Pöchlitz Phone: +43 2742 2000 E-Mail: ds@dsi.at</small>	
		<small>Format A3 Blatt 1</small>	